



US009117783B2

(12) **United States Patent**
Jin

(10) **Patent No.:** **US 9,117,783 B2**
(45) **Date of Patent:** **Aug. 25, 2015**

(54) **ORGANIC LIGHT EMITTING DIODE DISPLAY INCLUDING A GATE INSULATING LAYER SUPPORTING A DRIVING VOLTAGE LINE AND A DATA LINE**

(71) Applicant: **Samsung Display Co., Ltd.**, Yongin (KR)

(72) Inventor: **Min-Hyun Jin**, Yongin (KR)

(73) Assignee: **Samsung Display Co., Ltd.**, Yongin (KR)

(*) Notice: Subject to any disclaimer, the term of this patent is extended or adjusted under 35 U.S.C. 154(b) by 0 days.

(21) Appl. No.: **14/199,411**

(22) Filed: **Mar. 6, 2014**

(65) **Prior Publication Data**
US 2014/0353629 A1 Dec. 4, 2014

(30) **Foreign Application Priority Data**
May 30, 2013 (KR) 10-2013-0062058

(51) **Int. Cl.**
H01L 27/32 (2006.01)

(52) **U.S. Cl.**
CPC **H01L 27/3262** (2013.01); **H01L 27/3265** (2013.01); **H01L 27/3276** (2013.01)

(58) **Field of Classification Search**
CPC . H01L 51/56; H01L 51/5056; H01L 51/3262; H01L 51/0072; H01L 51/5072
USPC 257/40, 59, 72, 286
See application file for complete search history.

(56) **References Cited**

U.S. PATENT DOCUMENTS

7,646,044 B2* 1/2010 Huh et al. 257/286
2011/0227896 A1* 9/2011 Hwang 345/211

FOREIGN PATENT DOCUMENTS

KR 10-0642491 11/2006
KR 10-2010-0049385 5/2010
KR 10-2011-0042516 4/2011

* cited by examiner

Primary Examiner — Kyoung Lee

Assistant Examiner — Charles R Peters

(74) *Attorney, Agent, or Firm* — H.C. Park & Associates, PLC

(57) **ABSTRACT**

An organic light emitting diode (OLED) display including: a substrate; a semiconductor layer disposed on the substrate and including a switching semiconductor layer and a driving semiconductor layer connected to the switching semiconductor layer; a first gate insulating layer disposed on the semiconductor layer; a switching gate electrode and a driving gate electrode disposed on the first gate insulating layer and respectively overlapping with the switching semiconductor layer and the driving semiconductor layer; a second gate insulating layer disposed on the switching gate electrode and the driving gate electrode; a driving voltage line configured to transmit a driving voltage and disposed on the second gate insulating layer; an interlayer insulating layer disposed on the driving voltage line and the second gate insulating layer; and a data line configured to transmit a data signal and disposed on the interlayer insulating layer.

15 Claims, 5 Drawing Sheets

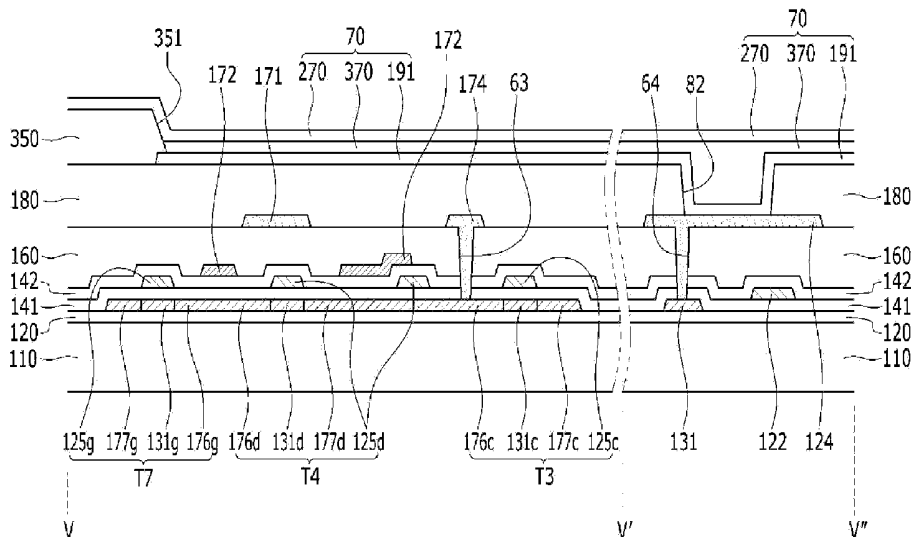

FIG. 2

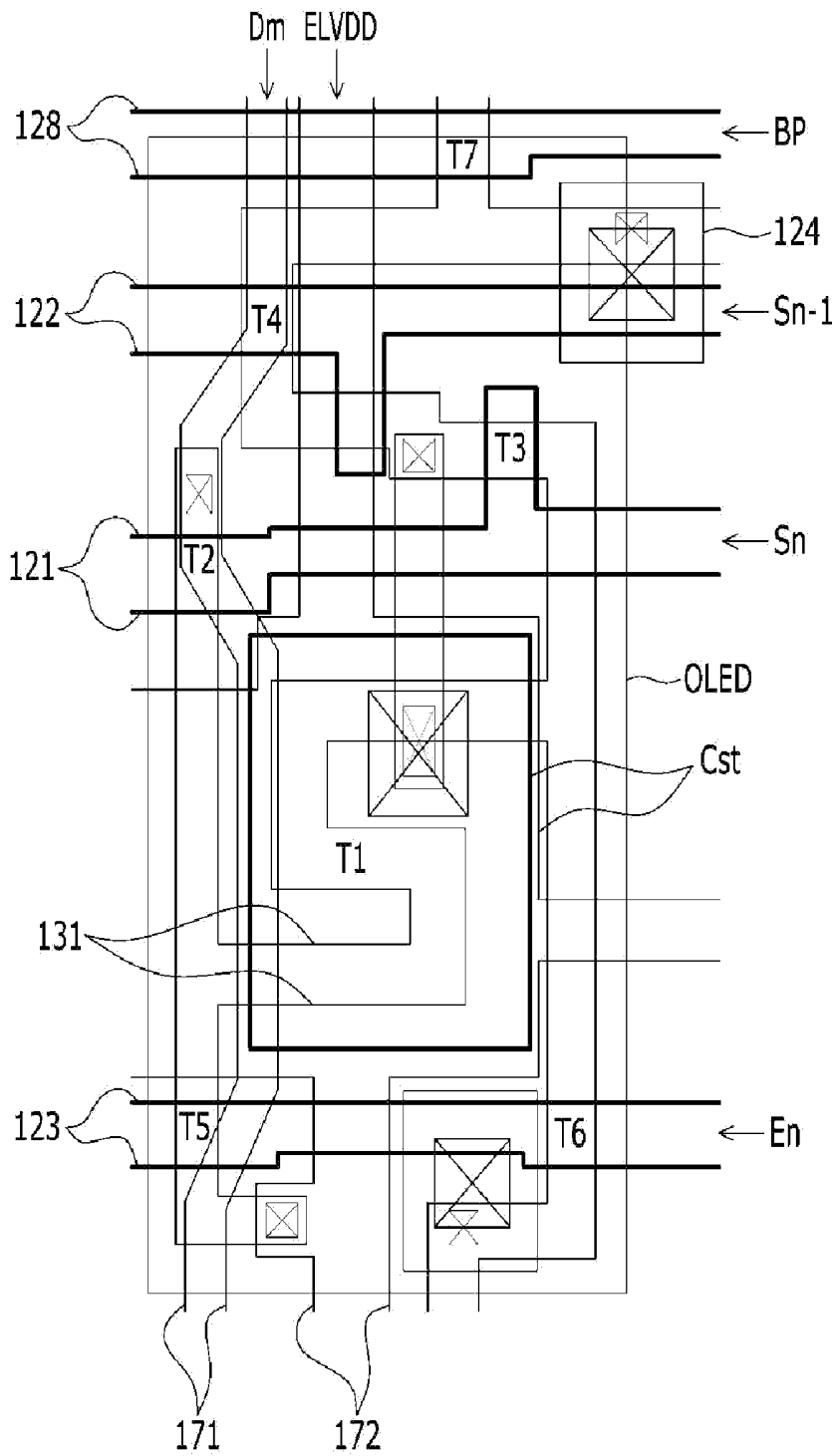

FIG. 3

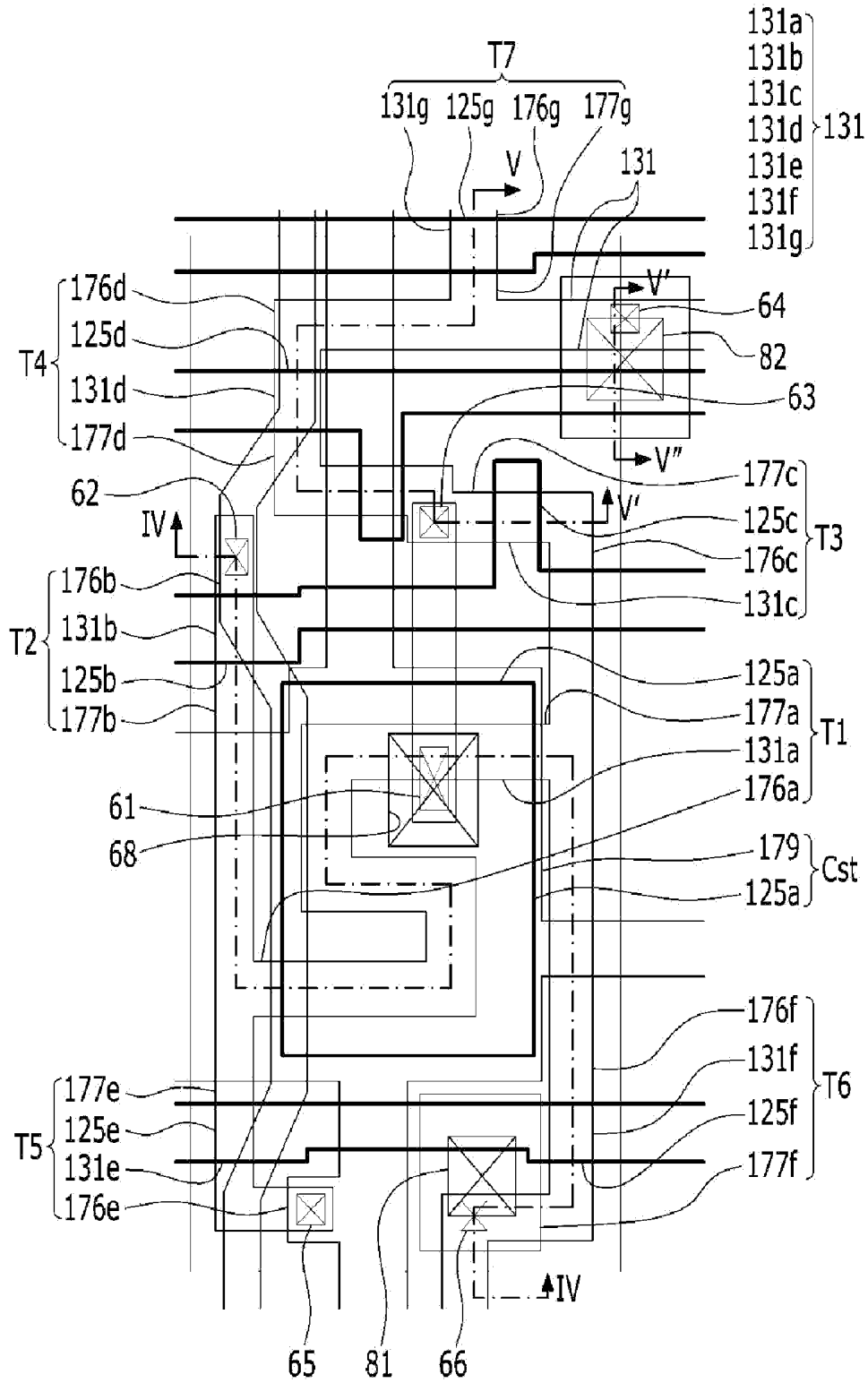

FIG. 4

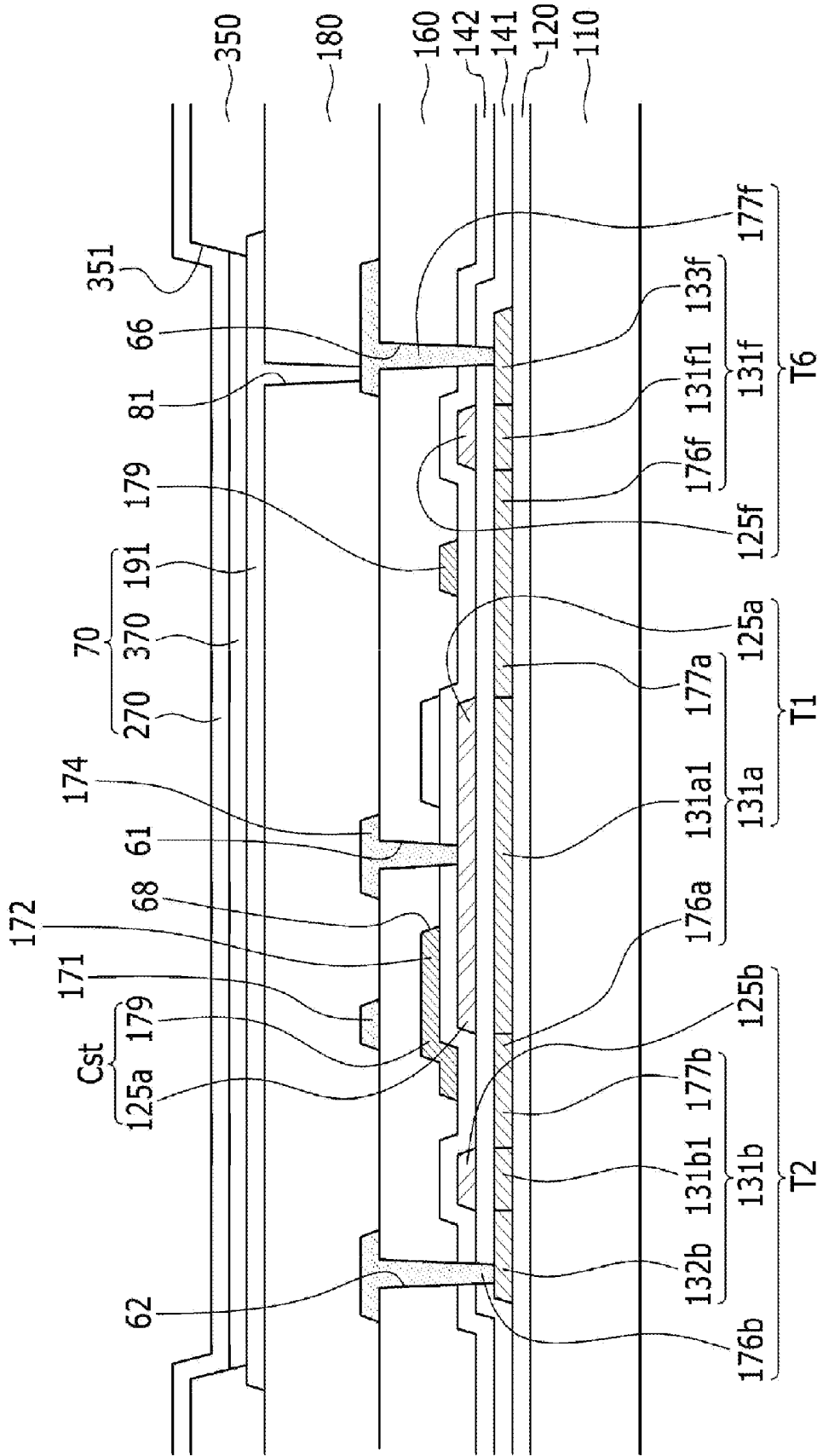
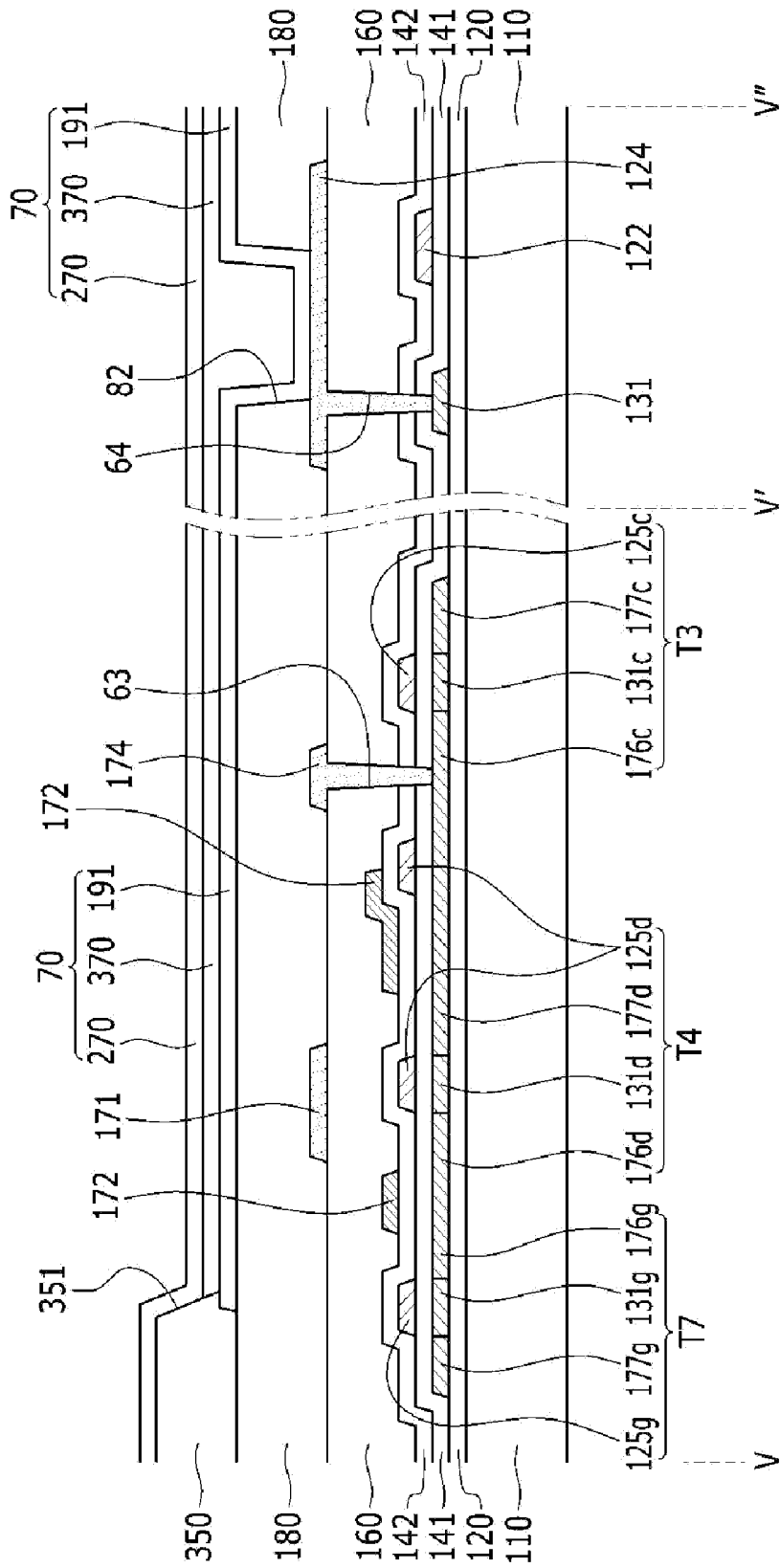

FIG. 5



**ORGANIC LIGHT EMITTING DIODE
DISPLAY INCLUDING A GATE INSULATING
LAYER SUPPORTING A DRIVING VOLTAGE
LINE AND A DATA LINE**

CROSS-REFERENCE TO RELATED
APPLICATION

This application claims priority to and the benefit of Korean Patent Application No. 10-2013-0062058 filed in the Korean Intellectual Property Office on May 30, 2013, the entire contents of which are incorporated herein by reference.

BACKGROUND OF THE INVENTION

1. Field

Exemplary embodiments of the present invention relate to an organic light emitting diode (OLED) display.

2. Discussion of the Background

An organic light emitting diode display includes two electrodes and an organic emission layer interposed therebetween, wherein electrons injected from a cathode that is one electrode and holes injected from an anode that is the other electrode are bonded to each other in the organic emission layer to form excitons, and light is emitted while the excitons discharge energy.

The organic light emitting diode display includes a plurality of pixels including an organic light emitting diode that is formed of a cathode, an anode, and an organic emission layer, and a plurality of transistors and storage capacitors for driving the organic light emitting diode are formed in each pixel. The plurality of transistors includes a switching transistor and a driving transistor.

When light emitted from the organic light emitting diode is displayed, the light has a range from a black color to a white color according to a driving current I_d flowing through the organic light emitting diode, an interval between a gate voltage displaying the black color and a gate voltage displaying the white color is defined as a driving range of the gate voltage. The higher the resolution of the organic light emitting diode display is, the smaller the size of each pixel is, and thus an amount of flowing current per pixel is reduced such that a driving range of a gate voltage applied to a gate electrode of the switching transistor and the driving transistor becomes narrow. Accordingly, it is difficult to adjust the magnitude of the gate voltage V_{gs} applied to the driving transistor so as to ensure a large grayscale range.

Also, as the organic light emitting diode (OLED) display becomes high resolution, the size of each pixel is decreased such that an interval between the driving voltage line and the data line that are formed with the same layer is decreased, and then a short between the driving voltage line and the data line may be easily generated, and the shorter distances are vulnerable to particles.

The above information disclosed in this Background section is only for enhancement of understanding of the background of the invention and therefore it may contain information that does not form the prior art that is already known in this country to a person of ordinary skill in the art.

BRIEF SUMMARY OF THE INVENTION

Exemplary embodiments of the present invention relates to an organic light emitting diode (OLED) display realizing high resolution by forming a driving voltage line and a data line with different layers.

Additional features of the invention will be set forth in the description which follows, and in part will be apparent from the description, or may be learned by practice of the invention.

Exemplary embodiments of the present invention provide an organic light emitting diode (OLED) display including: a substrate; a semiconductor layer disposed on the substrate and including a switching semiconductor layer and a driving semiconductor layer connected to the switching semiconductor layer; a first gate insulating layer disposed on the semiconductor layer; a switching gate electrode and a driving gate electrode disposed on the first gate insulating layer and respectively overlapping with the switching semiconductor layer and the driving semiconductor layer; a second gate insulating layer disposed on the switching gate electrode and the driving gate electrode; a driving voltage line configured to transmit a driving voltage and disposed on the second gate insulating layer; an interlayer insulating layer disposed on the driving voltage line and the second gate insulating layer; and a data line configured to transmit a data signal and disposed on the interlayer insulating layer.

Exemplary embodiments of the present invention provide an OLED display including: a semiconductor layer disposed on the substrate and comprising a switching semiconductor layer and a driving semiconductor layer connected to the switching semiconductor layer; a gate insulating layer disposed on the semiconductor layer; a driving voltage line configured to transmit a driving voltage; a data line configured to transmit a data signal; and an interlayer insulating layer to space-apart the driving voltage line and the data line, wherein the gate insulating layer supports the driving voltage line, the data line and the interlayer insulating layer.

According to exemplary embodiments of the present invention, by forming the driving voltage line and the data line, a short between the driving voltage line and the data line may be prevented thereby realizing high resolution.

According to exemplary embodiments, by forming the driving semiconductor layer with the curved shape, a long driving semiconductor layer may be formed in a narrow space such that the driving range of the gate voltage applied to the driving gate electrode may be increased. Therefore, a grayscale of light emitted from an organic light emitting diode (OLED) can be more finely controlled by changing the magnitude of the gate voltage, and as a result, it is possible to increase the resolution of the organic light emitting diode display and improve display quality.

It is to be understood that both the foregoing general description and the following detailed description are exemplary and explanatory and are intended to provide further explanation of the invention as claimed.

BRIEF DESCRIPTION OF THE DRAWINGS

The accompanying drawings, which are included to provide a further understanding of the invention and are incorporated in and constitute a part of this specification, illustrate exemplary embodiments of the invention, and together with the description serve to explain the principles of the invention.

FIG. 1 is an exemplary circuit of one pixel of an organic light emitting diode (OLED) display according to exemplary embodiments of the present invention.

FIG. 2 is a schematic view of a plurality of transistors and capacitors of an organic light emitting diode (OLED) display according to exemplary embodiments of the present invention.

FIG. 3 is a detailed layout view of FIG. 2.

FIG. 4 is a cross-sectional view of the organic light emitting diode (OLED) display of FIG. 3 taken along the line IV-IV.

FIG. 5 is a cross-sectional view of the organic light emitting diode (OLED) display of FIG. 3 taken along the lines V-V' and V'-V".

DETAILED DESCRIPTION OF THE ILLUSTRATED EMBODIMENTS

The invention is described more fully hereinafter with reference to the accompanying drawings, in which exemplary embodiments of the invention are shown. This invention may, however, be embodied in many different forms and should not be construed as limited to the exemplary embodiments set forth herein. Rather, these exemplary embodiments are provided so that this disclosure is thorough, and will fully convey the scope of the invention to those skilled in the art. In the drawings, the size and relative sizes of layers and regions may be exaggerated for clarity. Like reference numerals in the drawings denote like elements.

In addition, the size and thickness of each configuration shown in the drawings are arbitrarily shown for better understanding and ease of description, but the present invention is not limited thereto.

In the drawings, the thickness of layers, films, panels, regions, etc., are exaggerated for clarity. In the drawings, for understanding and ease of description, the thickness of some layers and areas is exaggerated. It will be understood that when an element such as a layer, film, region, or substrate is referred to as being "on" another element, it can be directly on the other element or intervening elements may also be present.

In addition, unless explicitly described to the contrary, the word "comprise" and variations such as "comprises" or "comprising" will be understood to imply the inclusion of stated elements but not the exclusion of any other elements. It will be understood that when an element such as a layer, film, region, or substrate is referred to as being "on" another element, it can be directly on the other element or intervening elements may also be present, but does not essentially mean positioning on the upper side of the object portion based on a gravity direction.

Further, in the specification, the phrase "on a flat surface" means when an object portion is viewed from above, and the phrase "on a cross-section" means when a cross-section taken by vertically cutting an object portion is viewed from the side.

An organic light emitting diode (OLED) display according to exemplary embodiments of the present invention will be described with reference to FIG. 1, FIG. 2, FIG. 3, FIG. 4 and FIG. 5.

FIG. 1 is an exemplary circuit of one pixel of an organic light emitting diode (OLED) display according to exemplary embodiments of the present invention.

As shown in FIG. 1, one pixel 1 of an organic light emitting diode (OLED) display according to exemplary embodiments of the present invention includes a plurality of signal lines 121, 122, 123, 124, 128, 171, and 172, a plurality of transistors T1, T2, T3, T4, T5, T6, and T7 connected to the plurality of signal lines, a storage capacitor (Cst), and an organic light emitting diode (OLED).

The transistors include a driving transistor T1, a switching transistor T2, a compensation transistor T3, an initialization transistor T4, an operation control transistor T5, a light emission control transistor T6, and a bypass transistor T7.

The signal lines include a scan line 121 transmitting a scan signal Sn, a previous scan line 122 transmitting a previous

scan signal Sn-1 to the initialization transistor T4, a light emission control line 123 transmitting a light emission control signal En to the operation control transistor T5 and the light emission control transistor T6, an initialization voltage line 124 initializing an initialization voltage Vint to the driving transistor T1, a bypass control line 128 transmitting a bypass signal BP to the bypass thin film transistor T7, a data line 171 crossing the scan line 121 and transmitting a data signal Dm, and a driving voltage line 172 transmitting a driving voltage ELVDD and parallel to a data line 171.

A gate electrode G1 of the driving transistor T1 is connected to an end Cst1 of the storage capacitor Cst, a source electrode S1 of the driving transistor T1 is connected via the operation control transistor T5 to the driving voltage line 172, and the drain electrode D1 of the driving transistor T1 is electrically connected via the light emission control transistor T6 to an anode of the organic light emitting diode (OLED). The driving transistor T1 receives a data signal Dm according to a switching operation of the pixel switching transistor T2 to supply a driving current Id to the organic light emitting diode (OLED).

A gate electrode G2 of the switching transistor T2 is connected to the scan line 121, a source electrode S2 of the switching transistor T2 is connected to the data line 171, and a drain electrode D2 of the switching transistor T2 is connected via the operation control transistor T5 to the driving voltage line 172 while being connected to the source electrode S1 of the driving transistor T1. The switching transistor T2 is turned on according to the scan signal Sn transferred through the scan line 121 to perform a switching operation of transferring the data signal Dm transferred to the data line 171 to the source electrode of the driving transistor T1.

A gate electrode G3 of the compensation transistor T3 is connected to the scan line 121, a source electrode S3 of the compensation transistor T3 is connected via the light emission control transistor T6 to the anode of the organic light emitting diode (OLED) while being connected to the drain electrode D1 of the driving transistor T1, and a drain electrode D3 of the compensation transistor T3 is connected to an end Cst1 of the storage capacitor Cst, a drain electrode D4 of the initialization transistor T4, and the gate electrode G1 of the driving transistor T1. The compensation transistor T3 is turned on according to the scan signal Sn transferred through the scan line 121 to connect the gate electrode G1 and the drain electrode D1 of the driving transistor T1 to each other, thus performing diode-connection of the driving transistor T1.

A gate electrode G4 of the initialization transistor T4 is connected to the prior scan line 122, a source electrode S4 of the initialization transistor T4 is connected to the initialization voltage line 124, and a drain electrode D4 of the initialization transistor T4 is connected to an end Cst1 of the storage capacitor Cst, the drain electrode D3 of the compensation transistor T3, and the gate electrode G1 of the driving transistor. The initialization transistor T4 is turned on according to the prior scan signal Sn-1 transferred through the prior scan line 122 to transfer the initialization voltage Vint to the gate electrode G1 of the driving transistor T1, thus performing an initialization operation for initializing the voltage of the gate electrode G1 of the driving transistor T1.

A gate electrode G5 of the operation control transistor T5 is connected to the light emission control line 123, a source electrode S5 of the operation control transistor T5 is connected to the driving voltage line 172, and a drain electrode D5 of the operation control transistor T5 is connected to the source electrode S1 of the driving transistor T1 and the drain electrode S2 of the switching transistor T2.

A gate electrode G6 of the light emission control transistor T6 is connected to the light emission control line 123, a source electrode S6 of the light emission control transistor T6 is connected to the drain electrode D1 of the driving transistor T1 and the source electrode S3 of the compensation transistor T3, and a drain electrode D6 of the light emission control transistor T6 is electrically connected to the anode of the organic light emitting diode (OLED). The operation control transistor T5 and the light emission control transistor T6 are simultaneously turned on according to the light emission control signal En transferred through the light emission control line 123 to transfer the driving voltage ELVDD to the organic light emitting diode (OLED), thus allowing the driving current Id to flow in the organic light emitting diode (OLED).

The bypass thin film transistor T7 includes a gate electrode G7 connected to the bypass control line 128, a source electrode S7 connected to the drain electrode D6 of the light emission control thin film transistor T6 and the anode of the organic light emitting diode (OLED), and a drain electrode D7 connected to the initialization voltage line 124 and the source electrode S4 of the initialization thin film transistor T4.

The other end Cst2 of the storage capacitor Cst is connected to the driving voltage line 172, and a cathode of the organic light emitting diode (OLED) is connected to a common voltage ELVSS. Accordingly, the organic light emitting diode (OLED) receives the driving current Id from the driving transistor T1 to emit light, thereby displaying an image.

Hereinafter, an operation process of one pixel of the organic light emitting diode display according to the exemplary embodiments of the present invention will be described in detail.

First, the prior scan signal Sn-1 of a low level is supplied through the prior scan line 122 during an initialization period. Then, the initialization transistor T4 is turned on corresponding to the prior scan signal Sn-1 of the low level, and the initialization voltage Vint is connected from the initialization voltage line 124 through the initialization transistor T4 to the gate electrode of the driving transistor T1 to initialize the driving transistor T1 by the initialization voltage Vint.

Subsequently, the scan signal Sn of the low level is supplied through the scan line 121 during a data programming period. Then, the switching transistor T2 and the compensation transistor T3 are turned on corresponding to the scan signal Sn of the low level.

In this case, the driving transistor T1 is diode-connected by the turned-on compensation transistor T3, and biased in a forward direction.

Then, a compensation voltage $Dm+V_{th}$ (V_{th} is a negative value) obtained by subtracting a threshold voltage V_{th} of the driving transistor T1 from the data signal Dm supplied from the data line 171 is applied to the gate electrode of the driving transistor T1.

The driving voltage ELVDD and the compensation voltage $Dm+V_{th}$ are applied to both ends of the storage capacitor Cst, and a charge corresponding to a difference between voltages at both ends is stored in the storage capacitor Cst. Thereafter, the level of the light emission control signal En supplied from the light emission control line 123 during the light emission period is changed from the high level to the low level. Then, the operation control transistor T5 and the light emission control transistor T6 are turned on by the light emission control signal En of the low level during the light emission period.

Then, the driving current Id is generated according to a difference between the voltage of the gate electrode of the

driving transistor T1 and the driving voltage ELVDD, and the driving current Id is supplied through the light emission control transistor T6 to the organic light emitting diode (OLED). A gate-source voltage V_{gs} of the driving transistor T1 is maintained at $(Dm+V_{th})-ELVDD$ by the storage capacitor Cst during the light emission period, and the driving current Id is proportional to a square of a value obtained by subtracting the threshold voltage from a source-gate voltage, that is, $(Dm-ELVDD)^2$, according to a current-voltage relationship of the driving transistor T1. Accordingly, the driving current Id is determined regardless of the threshold voltage V_{th} of the driving transistor T1.

At this time, the bypass transistor T7 receives the bypass signal BP from the bypass control line 128. The bypass signal BP is a voltage of a predetermined level capable of turning off the bypass transistor T7, and the bypass transistor T7 transmits the voltage of the transistor off level to the gate electrode G7 such that the bypass transistor T7 is always turned off and the portion of the driving current Id is discharged as the bypass current Ibp through the bypass transistor T7 in the off state.

The correct black luminance image is realized by using the bypass transistor to improve the contrast ratio. When a minimum current of the driving transistor displaying a black image flows as the driving current, if the organic light emitting diode (OLED) emits light, the black image is not normally displayed. Accordingly, the bypass transistor T7 of the organic light emitting diode (OLED) display according to exemplary embodiments of the present invention may disperse a portion of the minimum current of the driving transistor T1 as the bypass current Ibp to another current path besides the current path at the side of the organic light emitting diode (OLED). The minimum current of the driving transistor includes a current in a condition that the gate-source voltage V_{gs} of the driving transistor is smaller than the threshold voltage V_{th} such that the driving transistor is turned off. In the condition of turning off the driving transistor, the minimum driving current (e.g., a current of less than 10 pA) is transmitted to the organic light emitting diode (OLED) thereby displaying the image of the black luminance. When the minimum driving current displaying the black image flows, an influence of the distortion transmission of the bypass current Ibp is large. The influence of the driving current displaying an image, such as, a general image or a white image, flows. Accordingly, when the driving current flowing is for displaying a black image, the light emitting current Ioled of the organic light emitting diode (OLED) of which the current amount of the bypass current Ibp that is discharged through the bypass transistor T7 from the driving current Id is decreased has a minimum current amount of a degree capable of surely displaying the black image. Accordingly, the correct black luminance image is realized by using the bypass transistor thereby improving the contrast ratio.

Next, a detailed structure of the pixel of the organic light emitting diode (OLED) display shown in FIG. 1 will be described in detail with reference to FIG. 2, FIG. 3, FIG. 4 and FIG. 5 as well as FIG. 1.

FIG. 2 is a schematic view of a plurality of transistors and capacitors of an organic light emitting diode (OLED) display according to exemplary embodiments of the present invention, FIG. 3 is a detailed layout view of FIG. 2, FIG. 4 is a cross-sectional view of the organic light emitting diode (OLED) display of FIG. 3 taken along the line IV-IV, and FIG. 5 is a cross-sectional view of the organic light emitting diode (OLED) display of FIG. 3 taken along the lines V-V' and V'-V''.

As shown in FIG. 2, an organic light emitting diode (OLED) display according to exemplary embodiments of the present invention includes a scan line 121, a previous scan line 122, a light emission control line 123, and a bypass control line 128 respectively applying a scan signal Sn, a previous scan signal Sn-1, a light emission control signal En, and a bypass signal BP and formed according to a row direction, and includes a data line 171 and a driving voltage line 172 intersecting the scan line 121, the previous scan line 122, the light emission control line 123, and the bypass control line 128 and applying a data signal Dm and a driving voltage ELVDD to a pixel. An initialization voltage Vint (see FIG. 1) is transmitted from the organic light emitting diode (OLED) to the compensation transistor T3 through the initialization voltage line 124.

The pixel also includes a driving transistor T1, a switching transistor T2, a compensation transistor T3, an initialization transistor T4, an operation control transistor T5, a light emission control transistor T6, a bypass transistor T7, a storage capacitor Cst, and an organic light emitting diode (OLED).

The driving transistor T1, the switching transistor T2, the compensation transistor T3, the initialization transistor T4, the operation control transistor T5, the light emission control transistor T6, and the bypass transistor T7 are formed according to a semiconductor layer 131, and the semiconductor layer 131 is bent with various shapes. The semiconductor layer 131 may be formed of polysilicon or an oxide semiconductor. The oxide semiconductor may include any one of oxides including titanium (Ti), hafnium (Hf), zirconium (Zr), aluminum (Al), tantalum (Ta), germanium (Ge), zinc (Zn), gallium (Ga), tin (Sn), or indium (In) as a base, and complex oxides thereof, such as, zinc oxide (ZnO), indium-gallium-zinc oxide (InGaZnO4), indium-zinc oxide (Zn—In—O), zinc—tin oxide (Zn—Sn—O), indium-gallium oxide (In—Ga—O), indium-tin oxide (In—Sn—O), indium-zirconium oxide (In—Zr—O), indium-zirconium-zinc oxide (In—Zr—Zn—O), indium-zirconium-tin oxide (In—Zr—Sn—O), indium-zirconium-gallium oxide (In—Zr—Ga—O), indium-aluminum oxide (In—Al—O), indium-zinc-aluminum oxide (In—Zn—Al—O), indium-tin-aluminum oxide (In—Sn—Al—O), indium-aluminum-gallium oxide (In—Al—Ga—O), indium-tantalum oxide (In—Ta—O), indium-tantalum-zinc oxide (In—Ta—Zn—O), indium-tantalum-tin oxide (In—Ta—Sn—O), indium-tantalum-gallium oxide (In—Ta—Ga—O), indium-germanium oxide (In—Ge—O), indium-germanium-zinc oxide (In—Ge—Zn—O), indium-germanium-tin oxide (In—Ge—Sn—O), indium-germanium-gallium oxide (In—Ge—Ga—O), titanium-indium-zinc oxide (Ti—In—Zn—O), and hafnium-indium-zinc oxide (Hf—In—Zn—O). In the case where the semiconductor layer 131 is formed of the oxide semiconductor, a separate protective layer may be added to protect the oxide semiconductor, as the semiconductor layer 131 may be weak with regard to an external environment, such as, high temperatures.

The semiconductor layer 131 includes a channel region that is subjected to channel doping with an N-type impurity or a P-type impurity, and a source region and a drain region that are formed at respective sides of the channel region and formed by doping a doping impurity having a type that is opposite of the doping impurity doped in the channel region.

Hereinafter, a flat surface type of structure of the organic light emitting diode display according to the exemplary embodiments of the present invention will be first described in detail with reference to FIG. 2 and FIG. 3, and a lamination structure thereof will be described in detail with reference to FIG. 4 and FIG. 5.

Firstly, as shown in FIG. 2 and FIG. 3, the pixel 1 of the organic light emitting diode (OLED) display according to exemplary embodiments of the present invention includes the driving transistor T1, the switching transistor T2, the compensation transistor T3, the initialization transistor T4, the operation control transistor T5, the light emission control transistor T6, the bypass transistor T7, the storage capacitor Cst, and the organic light emitting diode (OLED). Transistors T1, T2, T3, T4, T5, T6, and T7 are formed according to the semiconductor layer 131. The semiconductor layer 131 includes a driving semiconductor layer 131a formed at the driving transistor T1, a switching semiconductor layer 131b formed at the switching transistor T2, a compensation semiconductor layer 131c formed at the compensation transistor T3, an initialization semiconductor layer 131d formed at the initialization transistor T4, an operation control semiconductor layer 131e formed at the operation control transistor T5, a light emission control semiconductor layer 131f formed at the light emission control transistor T6, and a bypass semiconductor layer 131g formed at the bypass thin film transistor T7.

The driving transistor T1 includes the driving semiconductor layer 131a, a driving gate electrode 125a, a driving source electrode 176a, and a driving drain electrode 177a.

The driving semiconductor layer 131a is bent, it may have a zigzag shape, and may be disposed with a “S” shape. As described above, by forming the driving semiconductor layer 131a of the curved shape, a long driving semiconductor layer 131a may be formed in a narrow space. Accordingly, a long driving channel region 131a1 (FIG. 4) of the driving semiconductor layer 131a may be formed such that a driving range of the gate voltage applied to the driving gate electrode 125a is broadened. Therefore, since the driving range of the gate voltage is broad, a grayscale of light emitted from an organic light emitting diode (OLED) can be more finely controlled by changing the magnitude of the gate voltage, and as a result, it is possible to increase the resolution of the organic light emitting diode display and improve display quality. By varying the shape of the driving semiconductor layer 131a, various exemplary embodiments of “ Σ ”, “S”, “M”, and “W” shapes are possible.

The driving source electrode 176a corresponds to the driving source region 176a doped with the impurity in the driving semiconductor layer 131a, and the driving drain electrode 177a corresponds to the driving drain region 177a doped with the impurity in the driving semiconductor layer 131a. The driving gate electrode 125a overlaps the driving semiconductor layer 131a, and the driving gate electrode 125a is formed with the same layer as the scan line 121, the prior scan line 122, the light emission control line 123, a switching gate electrode 125b, a compensation gate electrode 125c, an initialization gate electrode 125d, an operation control gate electrode 125e, and a light emission control gate electrode 125f.

The switching transistor T2 includes the switching semiconductor layer 131b, the switching gate electrode 125b, a switching source electrode 176b, and a switching drain electrode 177b. The switching source electrode 176b as a portion of the data line 171 is connected to the switching semiconductor layer 131b through a contact hole 62 and is simultaneously connected to the data line 171, and the switching drain electrode 177b corresponds to the switching drain region 177b doped with the impurity in the switching semiconductor layer 131b.

The compensation transistor T3 includes the compensation semiconductor layer 131c, the compensation gate electrode 125c, a compensation source electrode 176c, and a compensation drain electrode 177c, the compensation source electrode 176c corresponds to the compensation source region

176c doped with the impurity in the compensation semiconductor layer **131c**, and the compensation drain electrode **177c** corresponds to the compensation drain region **177c** doped with the impurity.

The initialization transistor **T4** includes the initialization semiconductor layer **131d**, the initialization gate electrode **125d**, an initialization source electrode **176d**, and an initialization drain electrode **177d**. The initialization source electrode **176d** corresponds to the initialization source region **176d** doped with the impurity and the initialization drain electrode **177d** corresponds to the initialization drain region **177d** doped with the impurity.

The operation control transistor **T5** includes the operation control semiconductor layer **131e**, the operation control gate electrode **125e**, an operation control source electrode **176e**, and an operation control drain electrode **177e**. The operation control source electrode **176e** as a portion of the driving voltage line **172** is connected to the operation control semiconductor layer **131e** through a contact hole **65**, and the operation control drain electrode **177e** corresponds to the operation control drain region **177e** doped with the impurity in the operation control semiconductor layer **131e**.

The light emission control transistor **T6** includes the light emission control semiconductor layer **131f**, the light emission control gate electrode **125f**, a light emission control source electrode **176f**, and a light emission control drain electrode **177f**. The light emission control source electrode **176f** corresponds to the light emission control source region **176f** doped with the impurity in the light emission control semiconductor layer **131f**, and the light emission control drain electrode **177f** is connected to the light emission control semiconductor layer **131f** through a contact hole **66**.

The bypass thin film transistor **T7** includes the bypass semiconductor layer **131g**, a bypass gate electrode **125g**, a bypass source electrode **176g**, and a bypass drain electrode **177g**. The bypass source electrode **176g** corresponds to the bypass source region **176g** doped with the impurity in the bypass semiconductor layer **131g**, and the bypass drain electrode **177g** corresponds to the bypass drain region **177g** doped with the impurity in the bypass semiconductor layer **131g**. The bypass source electrode **176g** is directly connected to the light emission control drain region **133f**.

An end of the driving semiconductor layer **131a** of the driving transistor **T1** is connected to the switching semiconductor layer **131b** and the compensation semiconductor layer **131c**, and the other end of the driving semiconductor layer **131a** is connected to the operation control semiconductor layer **131e** and the light emission control semiconductor layer **131f**. Therefore, the driving source electrode **176a** is connected to the switching drain electrode **177b** and the operation control drain electrode **177e**, and the driving drain electrode **177a** is connected to the compensation source electrode **176c** and the light emission control source electrode **176f**.

The storage capacitor **Cst** includes a first storage electrode **125a** and a second storage electrode **179** disposed via a second gate insulating layer **142** interposed therebetween. The first storage capacitive plate **125a** is the driving gate electrode **125a**, and the second storage capacitive plate (second storage electrode) **179** is an enlarged portion of the driving voltage line **172**. Here, the second gate insulating layer **142** becomes a dielectric material, and the storage capacitance is determined by charges charged in the storage capacitor **Cst** and the voltage between two charging plates **125a** and **179**.

The first storage capacitive plate **125a** as the driving gate electrode **125a** passes through a capacitive opening **68** formed at the second storage capacitive plate **179**, and is connected to a connection member **174** through a contact hole

61 formed in the second gate insulating layer **142** and an interlayer insulating layer **160**. The connection member **174** is parallel to and is formed with the same layer as the data line **171**, and connects the driving gate electrode **125a** and the compensation semiconductor layer **131c** of the compensation thin film transistor **T3**.

The connection member **174** is connected to the compensation semiconductor layer **131c** of the compensation thin film transistor **T3** through a contact hole **63** formed in the first gate insulating layer **141**, the second gate insulating layer **142** and an interlayer insulating layer **160**.

Accordingly, the storage capacitor **Cst** stores a storage capacitance corresponding to a difference between the driving voltage **ELVDD** transmitted to the second storage capacitive plate **179** through the driving voltage line **172** and the gate voltage of the driving gate electrode **125a**.

The switching transistor **T2** is used as a switching element for selecting a pixel that is to emit light. The switching gate electrode **125b** is connected to the scan line **121**, the switching source electrode **176b** is connected to the data line **171**, and the switching drain electrode **177b** is connected to the driving transistor **T1** and the operation control transistor **T5**. The light emission control drain electrode **177f** of the light emission control transistor **T6** is directly connected to a pixel electrode **191** of the organic light emitting diode **70**.

Hereinafter, referring to FIG. 4 and FIG. 5, a structure of the organic light emitting diode display according to the exemplary embodiments of the present invention will be described in detail according to the lamination order.

The structure of the transistor will be described based on the driving transistor **T1**, the switching transistor **T2**, and the light emission control transistor **T6**. The compensation transistor **T3**, the initialization transistor **T4**, and the bypass transistor **T7** are the same as the deposition structure of the switching transistor **T2**, and the operation control transistor **T5** is the same as the deposition structure of the light emission control transistor **T6**, so the detailed description thereof is omitted.

A buffer layer **120** is formed on a substrate **110**, and the substrate **110** is formed of an insulating substrate made of glass, quartz, ceramics, plastics, or the like.

A driving semiconductor layer **131a**, a switching semiconductor layer **131b**, and a light emission control semiconductor layer **131f** are formed on the buffer layer **120**.

The driving semiconductor layer **131a** includes a driving channel region **131a1**, and the driving source region **176a** and the driving drain region **177a** facing each other with the driving channel region **131a1** interposed therebetween, the switching semiconductor layer **131b** includes a switching channel region **131b1**, and a switching source region **132b** and a switching drain region **177b** facing each other with the switching channel region **131b1** interposed therebetween, and the light emission control transistor **T6** includes a light emission control channel region **131f1**, the light emission control source region **176f**, and a light emission control drain region **133f**.

A first gate insulating layer **141** is formed on the switching semiconductor layer **131a**, the driving semiconductor layer **131b**, and the light emission control semiconductor layer **131f**. On the first gate insulating layer **141**, gate wires **121** (see FIG. 1), **122**, **123** (see FIGS. 1), **125a**, **125b**, and **125f** including the scan line **121** including the switching gate electrode **125b**, the previous scan line **122**, the light emission control line **123** including the light emission control gate electrode **125f**, and the driving gate electrode (the first storage capacitive plate) **125a** are formed.

The second gate insulating layer **142** is formed on the gate wires **121**, **122**, **123**, **125b**, and **125f** and the first gate insulating layer **141**. The first gate insulating layer **141** and the second gate insulating layer **142** are formed of silicon nitride (SiN_x) or silicon oxide (SiO₂).

A driving voltage line **172** including the second storage capacitive plate **179** (FIG. 4) is formed on the second gate insulating layer **142**. An interlayer insulating layer **160** is formed on the second gate insulating layer **142** and the driving voltage line **172**. The interlayer insulating layer **160** may be made of a ceramic-based material such as silicon nitride (SiN_x) or silicon oxide (SiO₂).

On the interlayer insulating layer **160**, data wires **171**, **176b**, **177f**, and **124** including a data line **171** including a switching source electrode **176b**, a light emission control drain electrode **177f**, and an initialization voltage line **124** are formed.

As described above, by forming the driving voltage line **172** and the data line **171** with the different layers, a short between the driving voltage line **172** and the data line **171** may be prevented thereby realizing high resolution.

The switching source electrode **176b** is connected to the switching semiconductor layer **131b** through the contact hole **62** formed in the interlayer insulating layer **160**, the first gate insulating layer **141**, and the second gate insulating layer **142**, the light emission control drain electrode **177f** is connected to the light emission control semiconductor layer **131f** through the contact hole **66** formed in the first gate insulating layer **141**, the second gate insulating layer **142**, and the interlayer insulating layer **160**, and the initialization voltage line **124** is connected to the semiconductor layer **131** through a contact hole **64** (see also FIG. 3) formed in the first gate insulating layer **141**, the second gate insulating layer **142**, and the interlayer insulating layer **160**.

A protective layer **180** covering the data wires **171**, **176b**, **177f**, and **124** is formed on the interlayer insulating layer **160**, and the pixel electrode **191** is formed on the protective layer **180**. The pixel electrode **191** is connected to the light emission control drain electrode **177f** through a contact hole **81** (see also FIG. 3) formed in the protective layer **180**, and the initialization voltage line **124** is connected to the pixel electrode **191** through a contact hole **82** (see also FIG. 3) formed in the protective layer **180**.

A barrier rib **350** is formed on an edge of the pixel electrode **191** and the protective layer **180**, and the barrier rib **350** has a barrier rib opening **351** through which the pixel electrode **191** is exposed. The barrier rib **350** may be made of a resin such as a polyacrylate and a polyimide, or of silica-based inorganic materials.

An organic emission layer **370** is formed on the pixel electrode **191** exposed through the barrier rib opening **351**, and a common electrode **270** is formed on the organic emission layer **370**. The organic light emitting diode **70** including the pixel electrode **191**, the organic emission layer **370**, and the common electrode **270** is formed as described above.

Herein, the pixel electrode **191** is an anode that is a hole injection electrode, and the common electrode **270** is a cathode that is an electron injection electrode. However, the exemplary embodiments according to the present invention are not limited thereto, and the pixel electrode **191** may be the cathode and the common electrode **270** may be the anode according to the driving method of the organic light emitting diode display. Holes and electrons are injected from the pixel electrode **191** and the common electrode **270** into the organic

emission layer **370**, and when an exciton that is a combination of an injected hole and an injected electron falls from an excited state to a ground state, light is emitted.

The organic emission layer **370** is formed of a low molecular weight organic material or a high molecular weight organic material such as PEDOT (poly(3,4-ethylenedioxythiophene)). Further, the organic emission layer **370** may be formed of a multilayer including one or more of an emission layer, a hole injection layer HIL, a hole transport layer HTL, an electron transport layer ETL, and an electron injection layer EIL. In the case where all the layers are included, the hole injection layer HIL is disposed on the pixel electrode **191** that is the anode, and the hole transport layer HTL, the emission layer, the electron transport layer ETL, and the electron injection layer EIL are sequentially laminated thereon.

The organic emission layer **370** may include a red organic emission layer emitting light having a red color, a green organic emission layer emitting light having a green color, and a blue organic emission layer emitting light having a blue color, and the red organic emission layer, the green organic emission layer, and the blue organic emission layer are respectively formed in a red pixel, a green pixel, and a blue pixel to implement a color image.

Further, the organic emission layer **370** may implement the color image by laminating all of the red organic emission layer, the green organic emission layer, and the blue organic emission layer in the red pixel, the green pixel, and the blue pixel together, and forming a red color filter, a green color filter, and a blue color filter for each pixel. As another example, a white organic emission layer emitting light having a white color may be formed in all of the red pixel, the green pixel, and the blue pixel, and the red color filter, the green color filter, and the blue color filter may be formed for each pixel to implement the color image. In the case where the color image is implemented by using the white organic emission layer and the color filter, deposition masks for depositing the red organic emission layer, the green organic emission layer, and the blue organic emission layer on each pixel, that is, the red pixel, the green pixel, and the blue pixel, may not be used.

A white organic emission layer described in another example may be formed of one organic emission layer, and includes a constitution in which a plurality of organic emission layers are laminated to emit light having the white color. For example, a constitution in which at least one yellow organic emission layer and at least one blue organic emission layer are combined to emit light having the white color, a constitution in which at least one cyan organic emission layer and at least one red organic emission layer are combined to emit light having the white color, a constitution in which at least one magenta organic emission layer and at least one green organic emission layer are combined to emit light having the white color, or the like, may be included.

A sealing member (not illustrated) for protecting the organic light emitting diode **70** may be formed on the common electrode **270**, may be sealed by a sealant on the substrate **110**, and may be formed of various materials, such as, glass, quartz, ceramic, plastics, and metal. Meanwhile, a sealing thin film layer may be formed by depositing an inorganic layer and an organic layer on the common electrode **270** while not using the sealant.

It will be apparent to those skilled in the art that various modifications and variation can be made in the present invention without departing from the spirit or scope of the invention. Thus, it is intended that the present invention cover the

13

modifications and variations of this invention provided they come within the scope of the appended claims and their equivalents.

What is claimed is:

1. An organic light emitting diode (OLED) display, comprising:
 - a substrate;
 - a semiconductor layer disposed on the substrate and comprising a switching semiconductor layer and a driving semiconductor layer;
 - a first gate insulating layer disposed on the semiconductor layer;
 - a switching gate electrode and a driving gate electrode disposed on the first gate insulating layer and respectively overlapping with the switching semiconductor layer and the driving semiconductor layer;
 - a second gate insulating layer disposed on the switching gate electrode and the driving gate electrode;
 - a driving voltage line configured to transmit a driving voltage and disposed on the second gate insulating layer;
 - an interlayer insulating layer disposed on the driving voltage line and the second gate insulating layer; and
 - a data line configured to transmit a data signal and disposed on the interlayer insulating layer.
2. The organic light emitting diode (OLED) display of claim 1, further comprising:
 - a storage capacitor overlapping with the driving gate electrode, wherein the storage capacitor comprises a first storage capacitive plate as the driving gate electrode; and
 - a second storage capacitive plate overlapping with the first storage capacitive plate and disposed on the second gate insulating layer.
3. The organic light emitting diode (OLED) display of claim 2, wherein the second storage capacitive plate comprises an enlarged portion of the driving voltage line.
4. The organic light emitting diode (OLED) display of claim 3, wherein the driving semiconductor layer is bent.
5. The organic light emitting diode (OLED) display of claim 4, further comprising:
 - a compensation thin film transistor configured to compensate a threshold voltage of the driving transistor and connected to the driving transistor; and
 - a connection member formed with the same layer as the data line and connecting the driving gate electrode and a compensation semiconductor layer of the compensation thin film transistor.
6. The organic light emitting diode (OLED) display of claim 5, wherein the driving gate electrode is connected to the connection member through a contact hole disposed in a capacitive opening disposed in the second storage capacitive plate, the second gate insulating layer, and the interlayer insulating layer.

14

7. The organic light emitting diode (OLED) display of claim 6, further comprising:
 - a protective layer disposed on the interlayer insulating layer and the data line; and
 - an organic light emitting diode (OLED) disposed on the protective layer.
8. An organic light emitting diode (OLED) display, comprising:
 - a semiconductor layer disposed on the substrate and comprising a switching semiconductor layer and a driving semiconductor layer;
 - a gate insulating layer disposed on the semiconductor layer;
 - a driving voltage line configured to transmit a driving voltage;
 - a data line configured to transmit a data signal;
 - an interlayer insulating layer to space-apart the driving voltage line and the data line,
 - a switching gate electrode overlapping the switching semiconductor layer disposed on the gate insulating layer;
 - a driving gate electrode overlapping the driving semiconductor layer disposed on the gate insulating layer;
 - a compensation thin film transistor configured to compensate a threshold voltage of the driving transistor and connected to the driving transistor; and
 - a connection member connecting the driving gate electrode and the compensation semiconductor layer of the compensation thin film transistor,
 wherein:
 - the gate insulating layer supports the driving voltage line, the data line, and the interlayer insulating layer; and
 - the driving semiconductor layer comprises the connection member.
9. The OLED display of claim 8, further comprising:
 - a substrate to support the semiconductor layer.
10. The OLED display of claim 8, wherein the interlayer insulating layer is disposed on the driving voltage line.
11. The OLED display of claim 8, wherein the interlayer insulating layer is disposed on the data line.
12. The OLED display of claim 8, wherein the driving voltage line comprises an enlarged portion to form a storage capacitive plate.
13. The organic light emitting diode (OLED) display of claim 8, wherein the driving semiconductor layer is bent.
14. The OLED display of claim 8, further comprising:
 - a second gate insulating layer disposed on the switching gate electrode and the driving gate electrode.
15. The OLED display of claim 8, further comprising:
 - a protective layer disposed on the interlayer insulating layer and the data line; and
 - an organic light emitting diode (OLED) disposed on the protective layer.

* * * * *

专利名称(译)	有机发光二极管显示器包括支撑驱动电压线和数据线的栅极绝缘层		
公开(公告)号	US9117783	公开(公告)日	2015-08-25
申请号	US14/199411	申请日	2014-03-06
[标]申请(专利权)人(译)	三星显示有限公司		
申请(专利权)人(译)	三星DISPLAY CO. , LTD.		
当前申请(专利权)人(译)	三星DISPLAY CO. , LTD.		
[标]发明人	JIN MIN HYUN		
发明人	JIN, MIN-HYUN		
IPC分类号	H01L27/32		
CPC分类号	H01L27/3262 H01L27/3265 H01L27/3276 G09F9/301 G09G3/3208 H01L27/3241 H01L27/3274 H01L51/5203		
审查员(译)	LEE , KYOUNG		
优先权	1020130062058 2013-05-30 KR		
其他公开文献	US20140353629A1		
外部链接	Espacenet USPTO		

摘要(译)

一种有机发光二极管 (OLED) 显示器，包括：基板；半导体层，设置在基板上，包括开关半导体层和连接到开关半导体层的驱动半导体层；第一栅极绝缘层，设置在半导体层上；开关栅电极和驱动栅电极，设置在第一栅极绝缘层上并分别与开关半导体层和驱动半导体层重叠；第二栅极绝缘层，设置在开关栅电极和驱动栅电极上；驱动电压线，配置为传输驱动电压并设置在第二栅极绝缘层上；层间绝缘层，设置在驱动电压线和第二栅极绝缘层上；数据线，被配置为传输数据信号并设置在层间绝缘层上。

